



Typ / Type : EHND 200-2 (LG/RD)		Art.-No. : B37-20020 / B37-20021	
U	400V (50Hz)	Δp_{fa} min	-- Pa
P ₂	0.25 kW	ΔI	-- %
I _N	0.66 A	I _A / I _N	4.0
n	2720 min ⁻¹		IP55
C _{400V}	-- μ F		01.430
t _R	-- °C		12 kg

Geräusche / Sound levels:

LWArel A-bewertet bei $V=0,5 \cdot V_{max}$ LWArel A-weighted at $V=0,5 \cdot V_{max}$	fM [Hz]						
	125	250	500	1K	2K	4K	8K
Ausblasseite 2-polig / outlet side 2-pole	-26	-13	-6	-5	-5	-12	-22
Ansaugseite 2-polig / inlet side 2-pole	-22	-12	-4	-5	-8	-13	-21

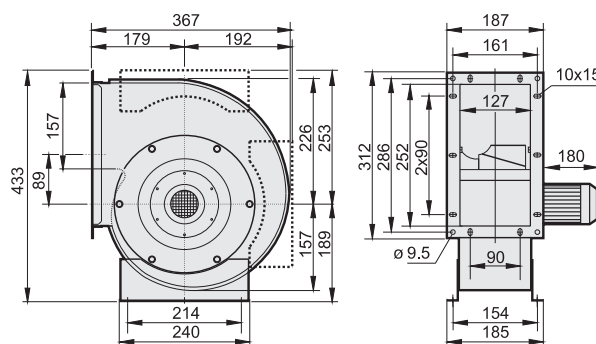

Zubehör / Accessories:

GS	ABF	ABS	ASS	ASF
Seite/Page	Seite/Page	Seite/Page	Seite/Page	Seite/Page
404	445	445	446	446